

INSTRUCTIONS DE MONTAGE
MONTAGEANLEITUNG
INSTRUCTIONS FOR ASSEMBLY
INSTRUCCIONES DE MONTAJE

VOLETS COULISSANTS MANUELS : 1 PANNEAU
SCHIEBEFENSTERLÄDEN : 1 FLÜGEL
SLIDING SHUTTERS – 1 PANEL
MALLORQUINAS CORREDERAS : 1 HOJA

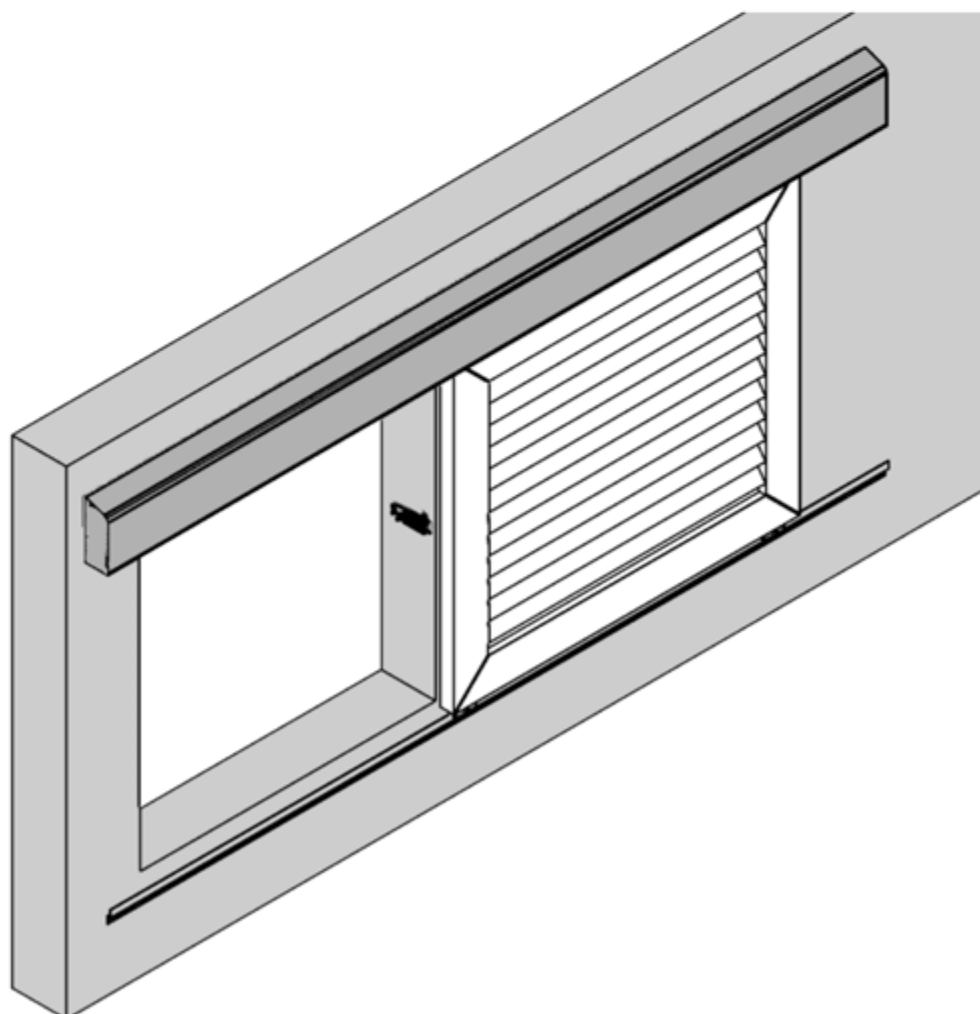

Poids maximal des panneaux Maximales Gewicht Maximum weight Peso máximo por hoja	80 Kg
Epaisseur des panneaux Ladendicke Shutter thickness Espesor de las hojas	27 - 40 mm



COMPOSITION - ZUSAMMENSETZUNG - COMPOSICIÓN

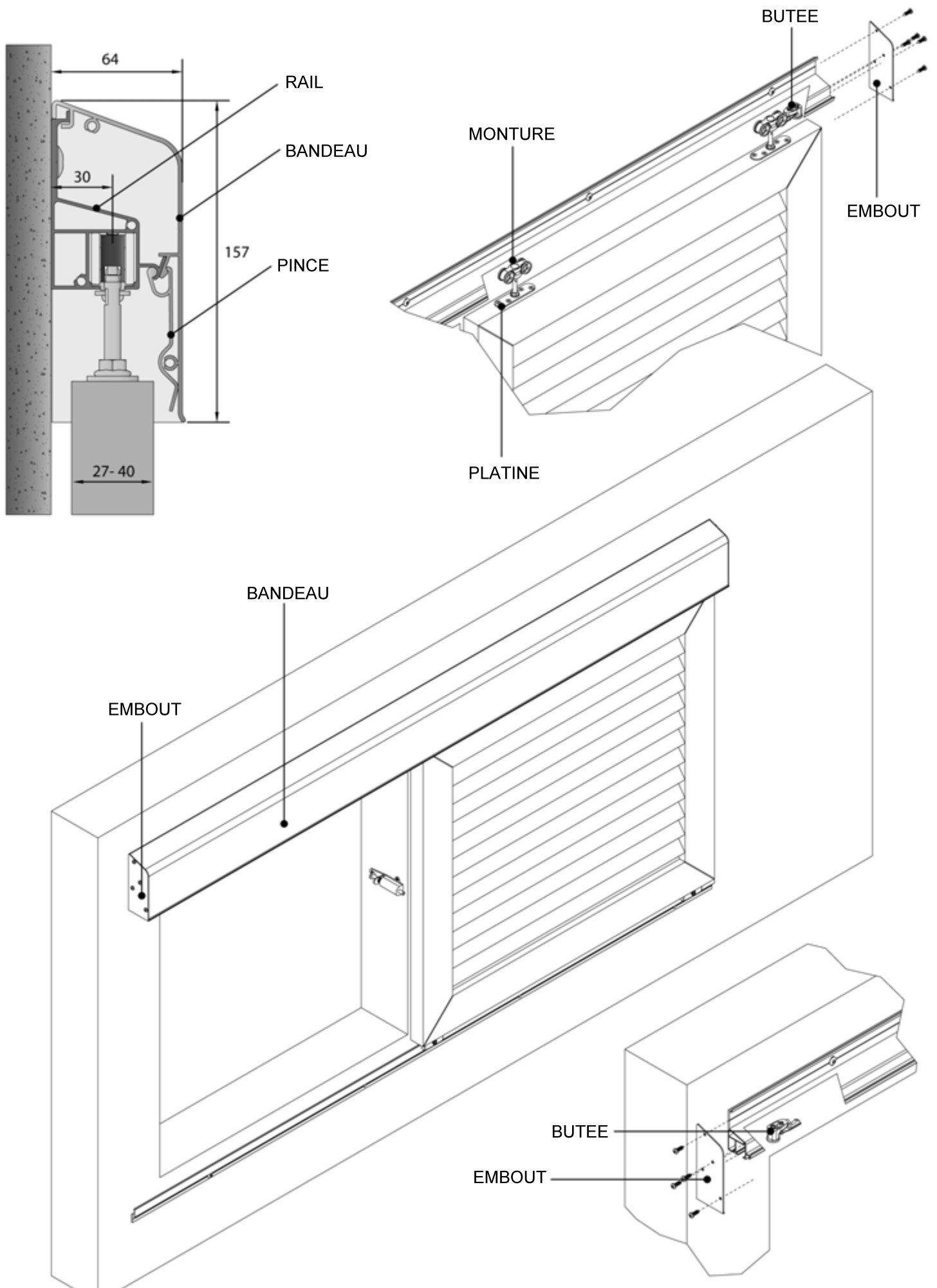

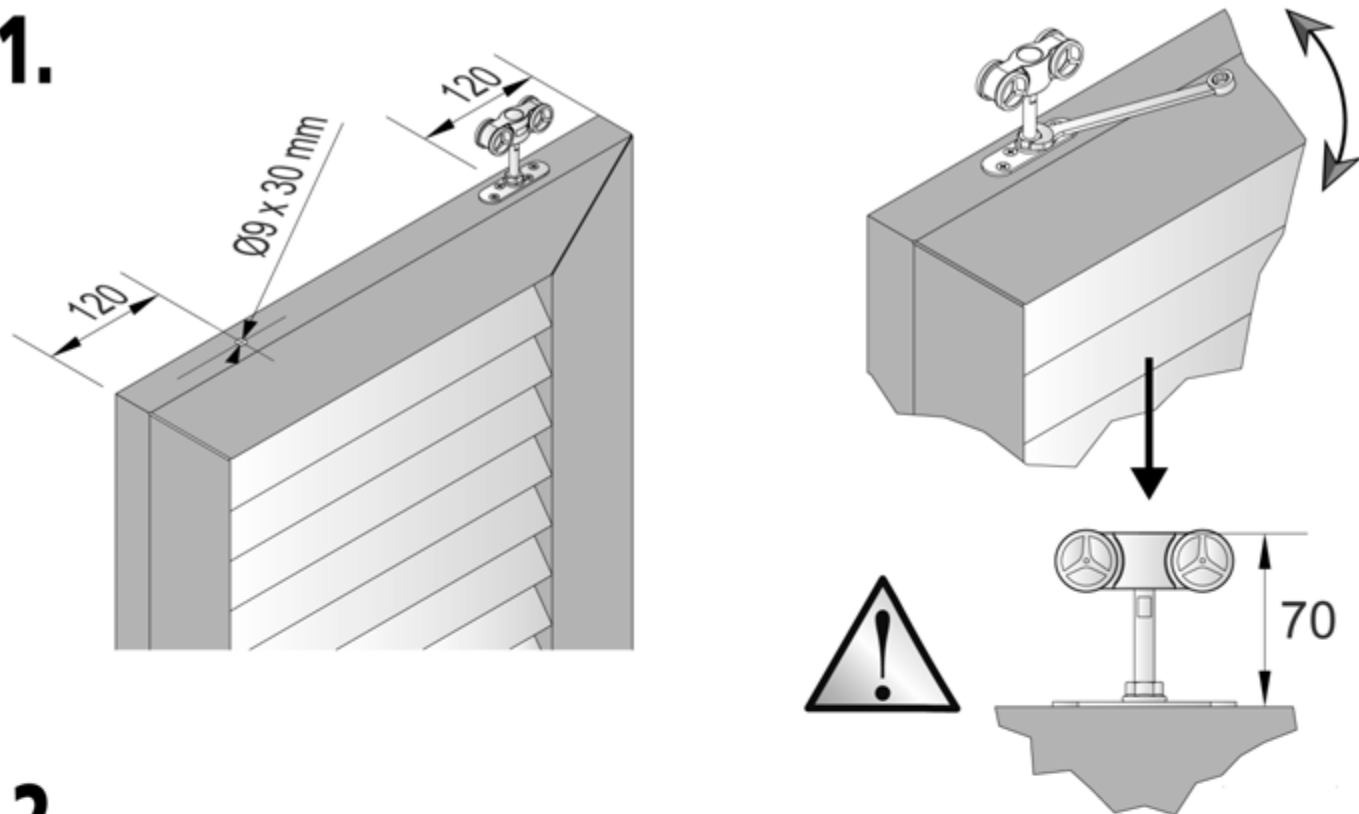
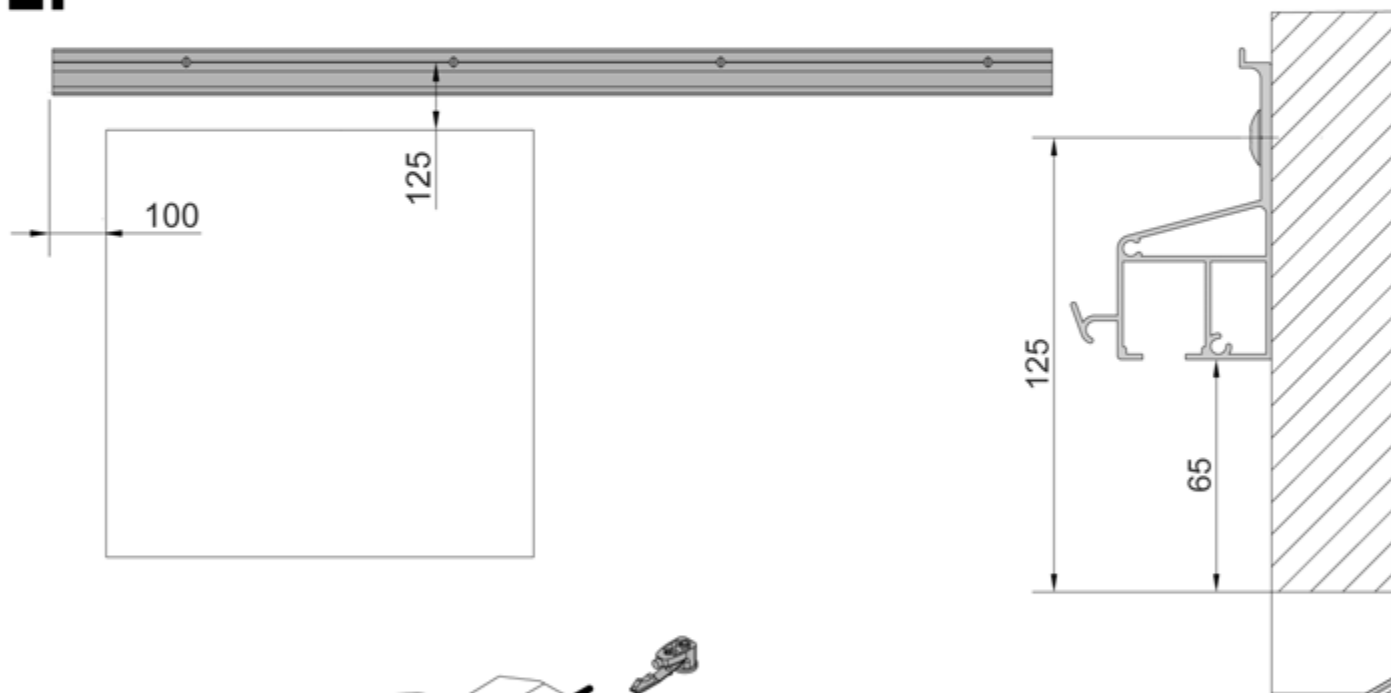
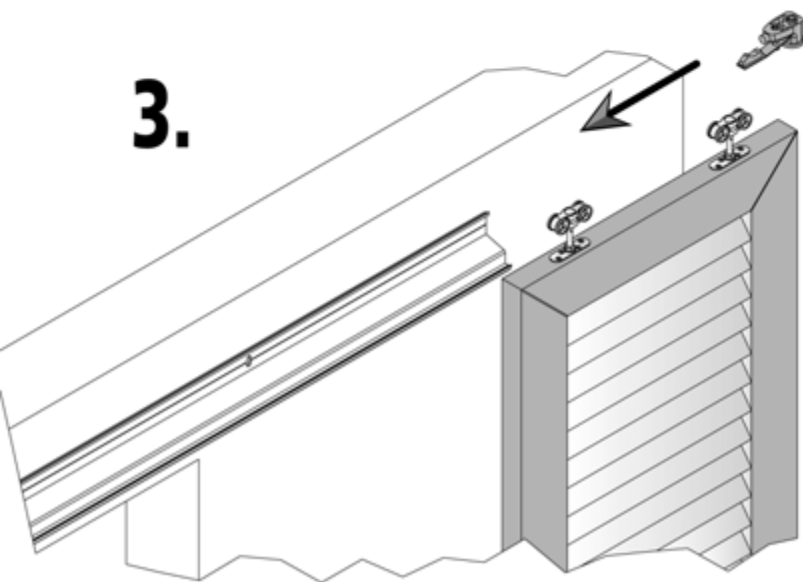
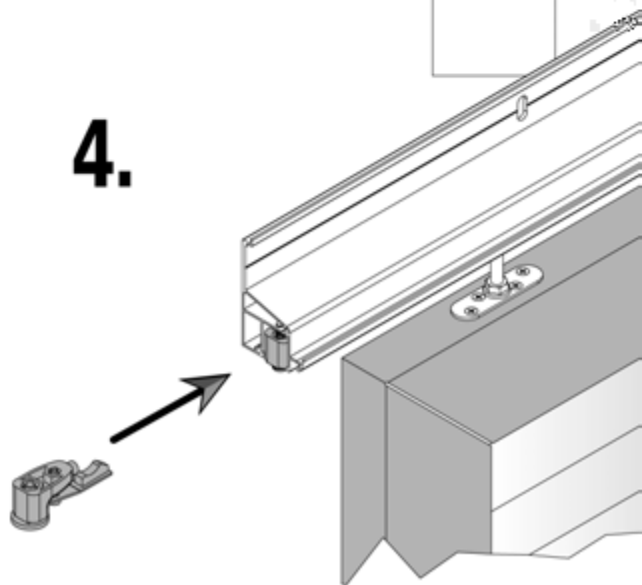
1.**2.****3.****4.**

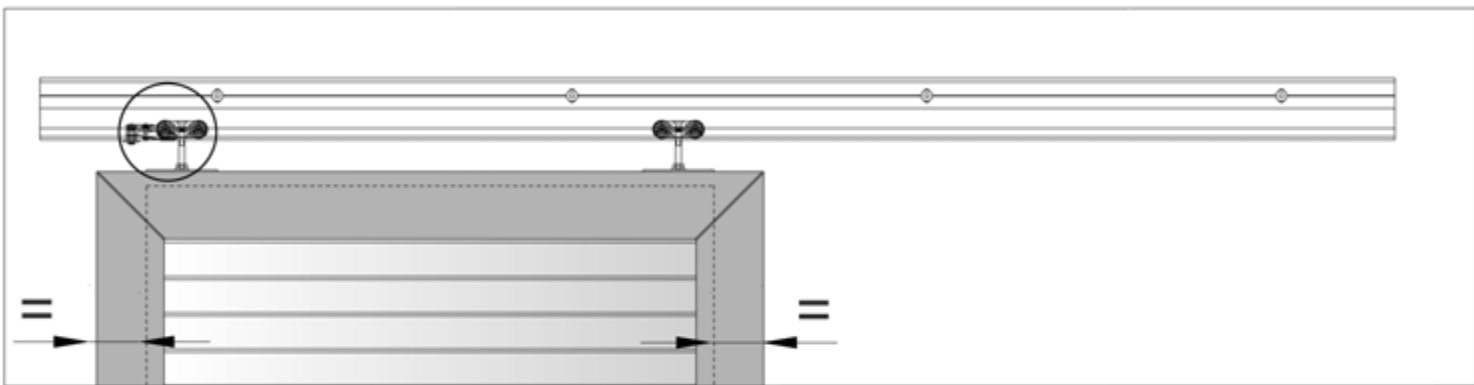
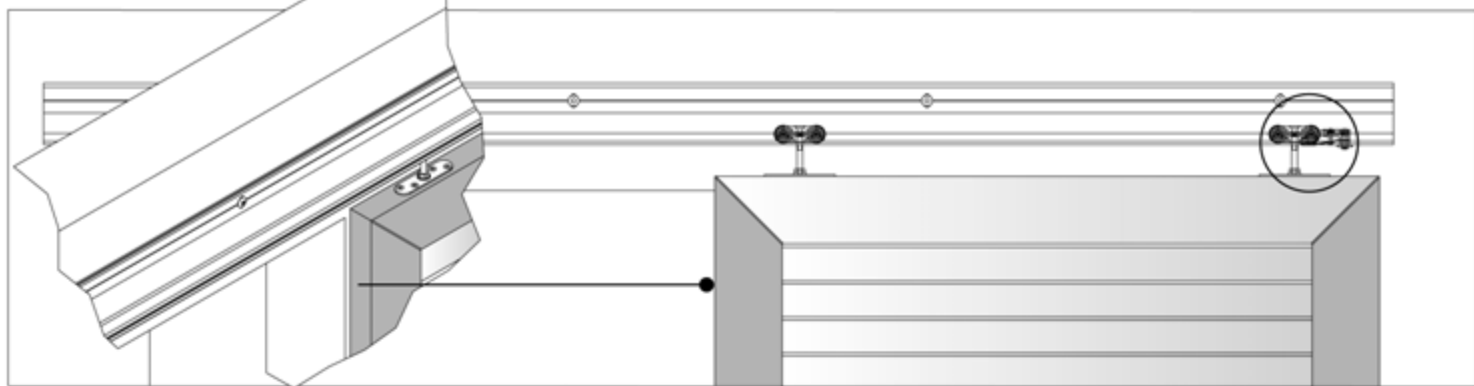

5.

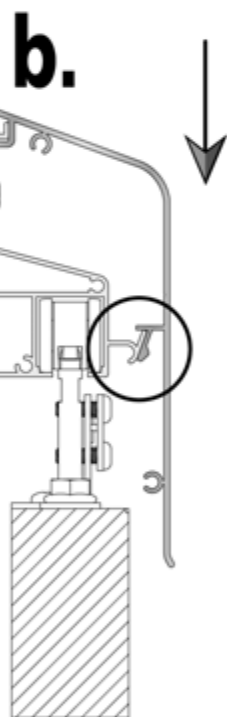
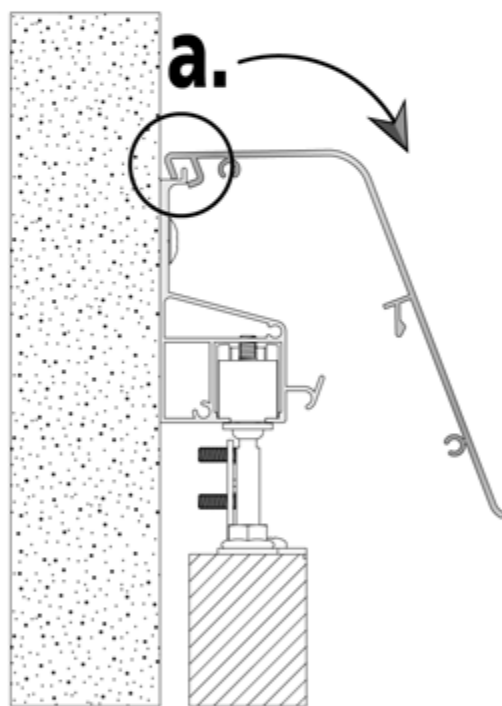
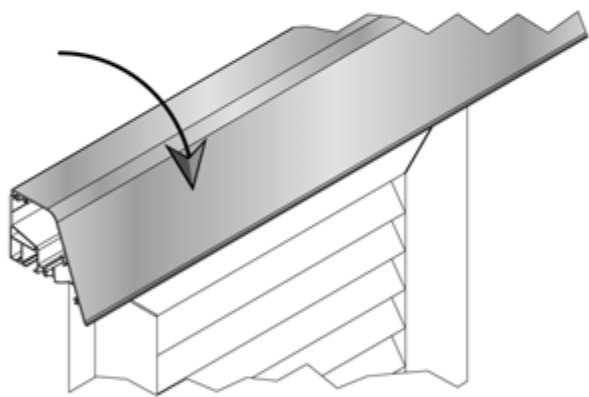

6.

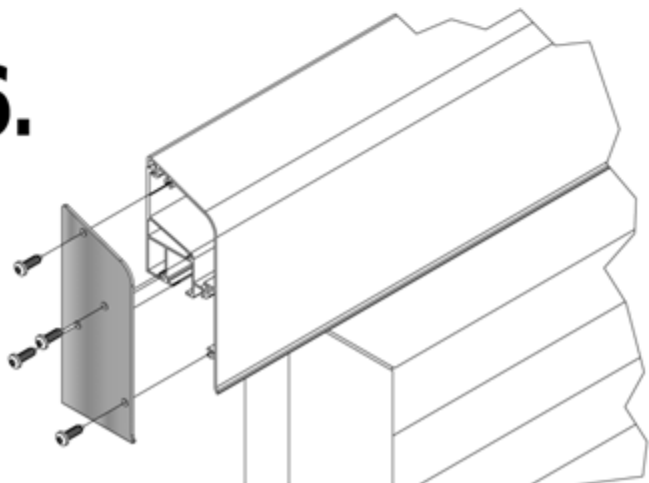

7.

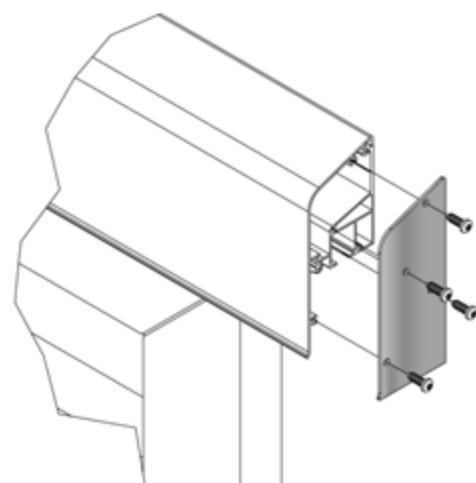

8.

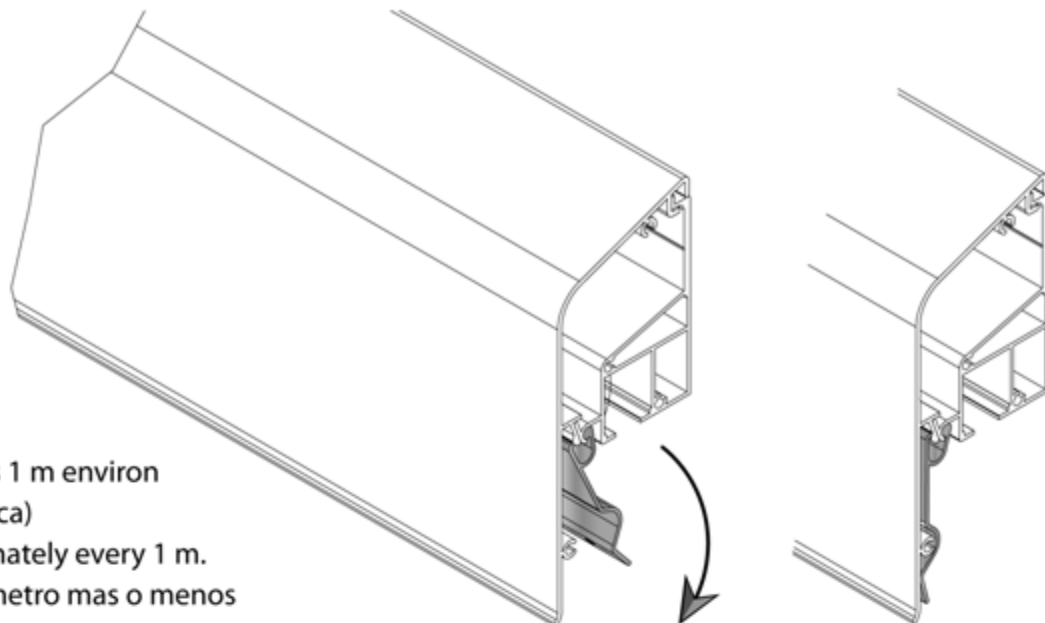

clipser une pince tous les 1 m environ
Aufclipsen jeder 1 m (cerca)
Clip the clamps approximately every 1 m.
Engatillar los clips cada metro mas o menos

9.

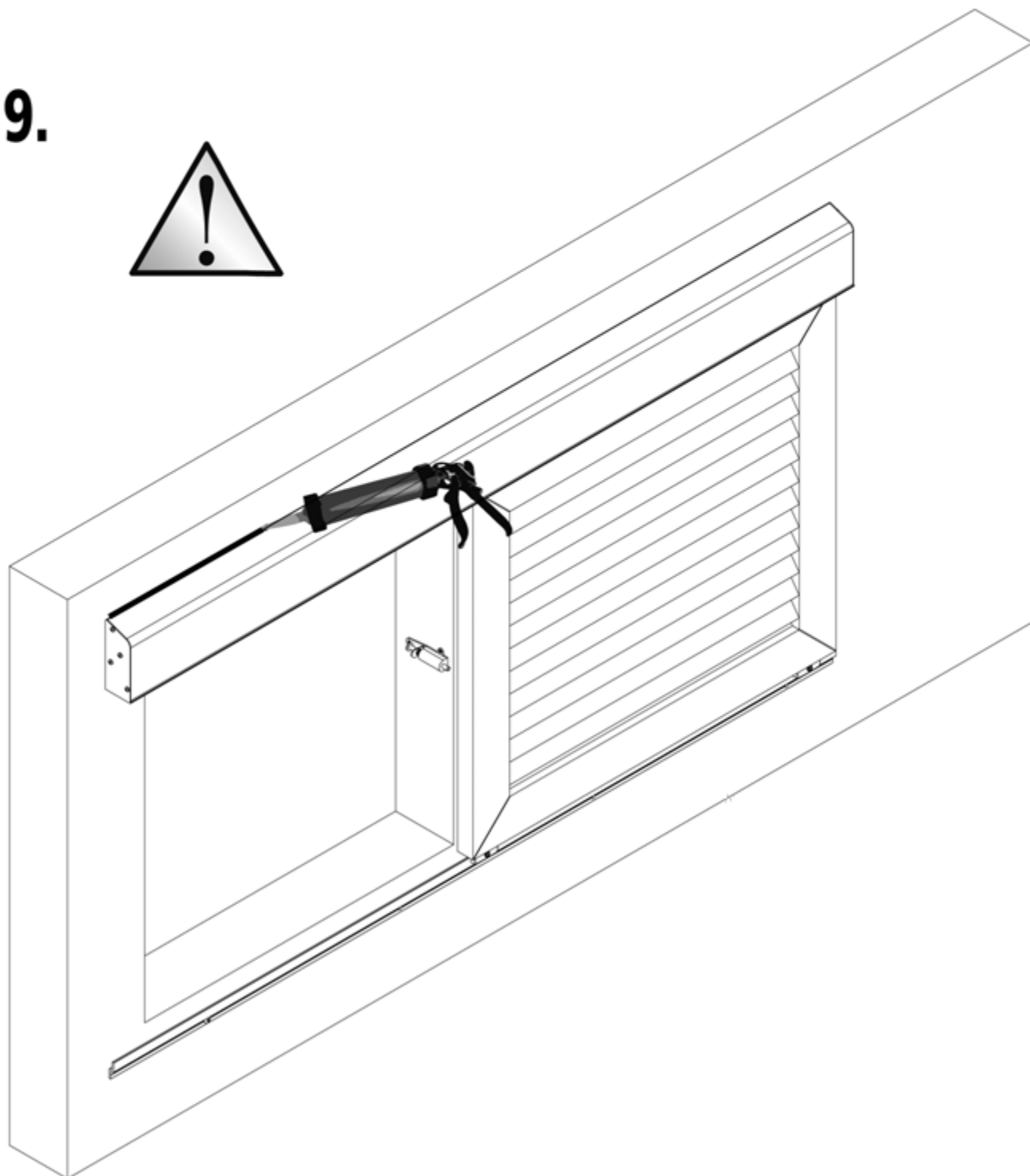

SOLUTIONS DE GUIDAGE EN FAÇADE / UNTERFÜHRUNGSLÖSUNGEN

SOLUTIONS OF GUIDING OF WALL FIXING / SOLUCIONES PARA EL GUIADO A LA PARED

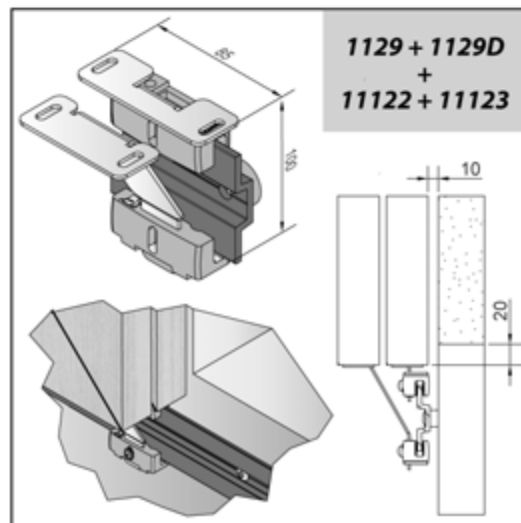
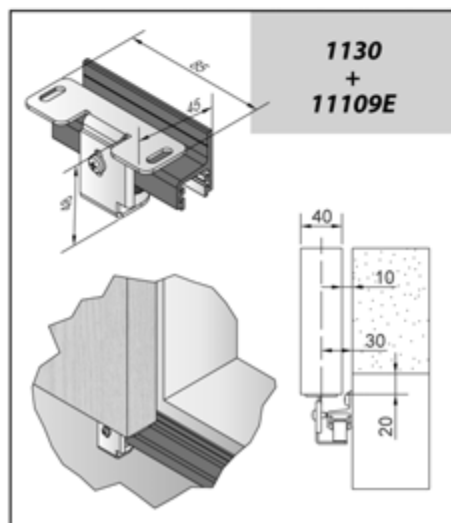
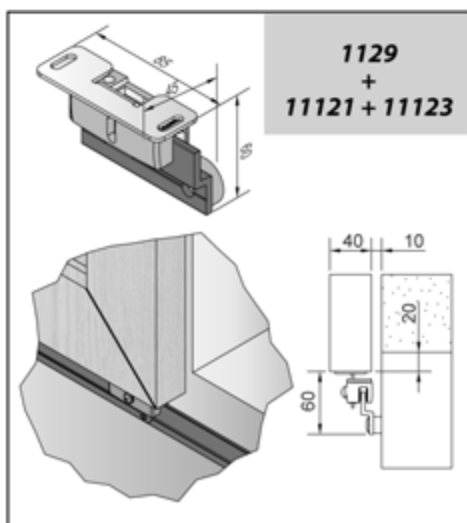
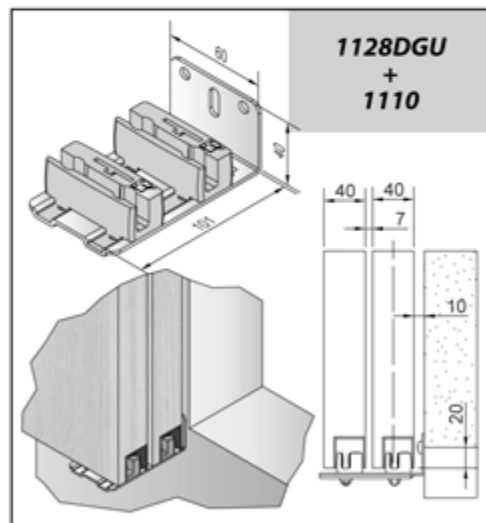
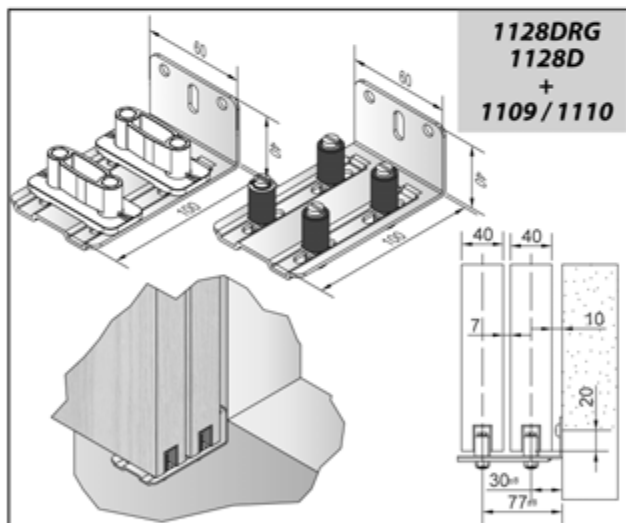
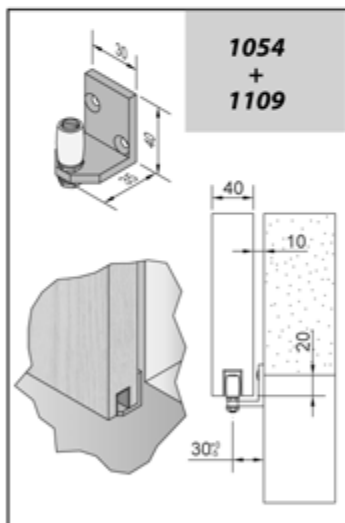
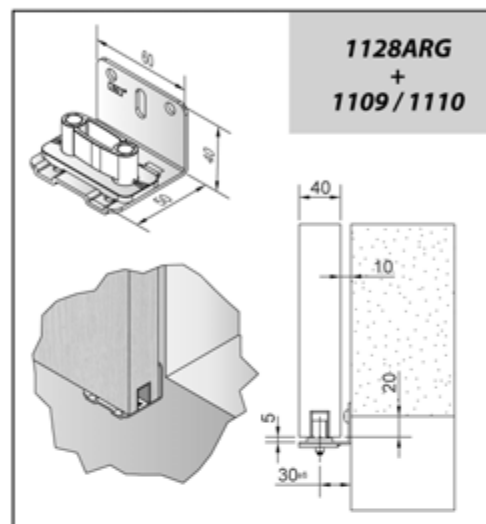
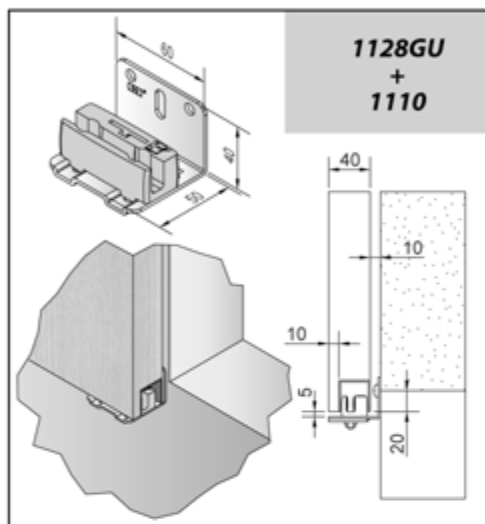
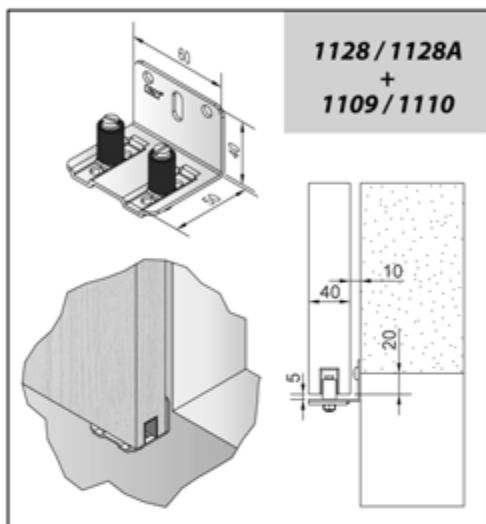
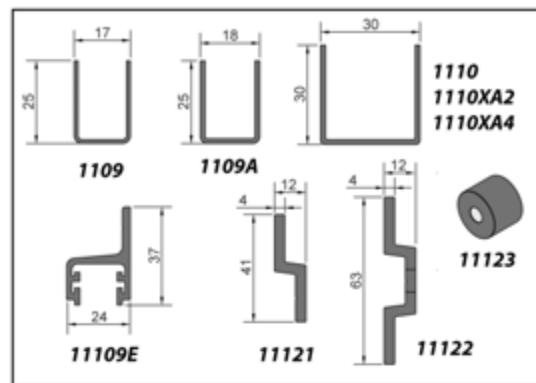
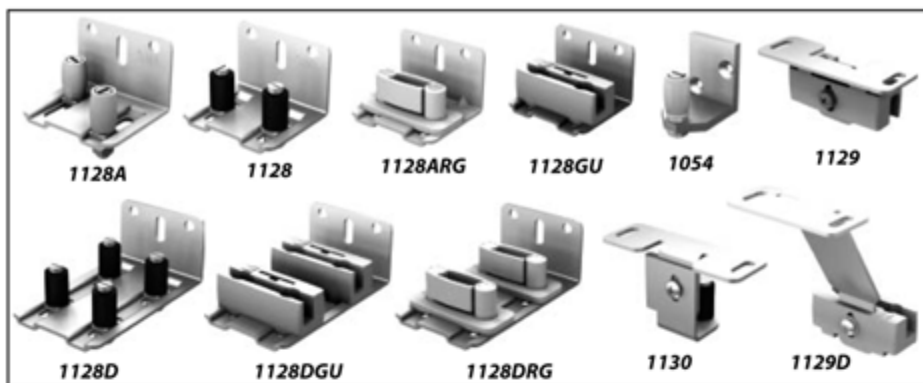

SOLUTIONS DE GUIDAGE AU SOL / FÜHRUNGSLÖSUNGEN BÜNDUNG IN DER LEIBUNG
SOLUTIONS OF LOWER GUIDING / SOLUCIONES PARA EL GUIADO AL SUELO

