



**SLID'UP**  
by MANTION

INSTRUCTION DE MONTAGE  
MONTAGEANLEITUNG  
INSTRUCTIONS FOR ASSEMBLY  
INSTRUCCIONES DE MONTAJE  
INSTRUKCJA MONTA U

**SLID'UP 1804**  
**SLID'UP 1806**

**2 x 50 KG**

PORTE D'INTÉRIEUR À MOTORISER  
INNENTÜR MIT ELEKTRO-ANTRIEB  
INTERIOR AUTOMATIC DOOR  
PUERTA DE INTERIOR MOTORIZADA

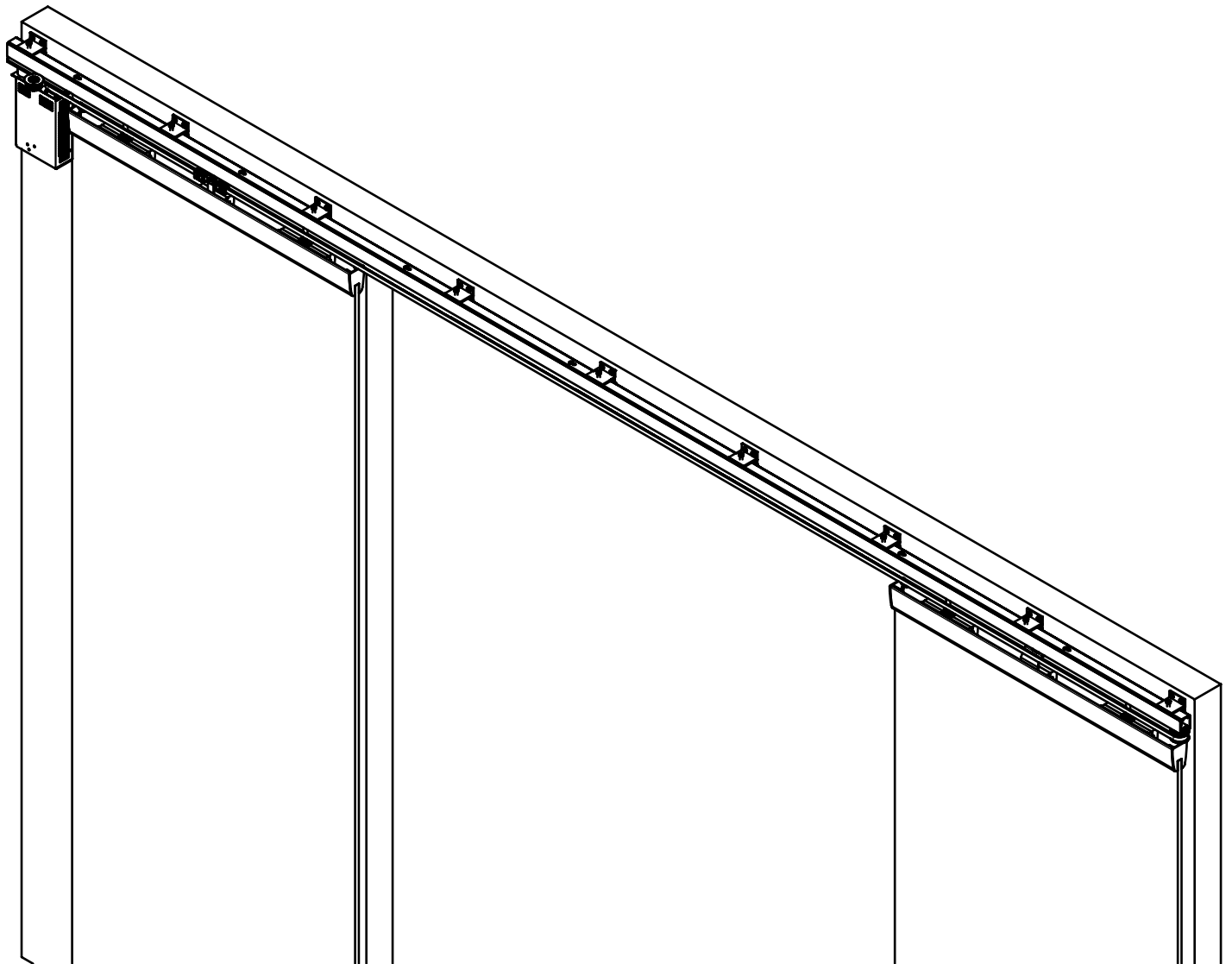

# COMPOSITION - ZUSAMMENSETZUNG - COMPOSICIÓN

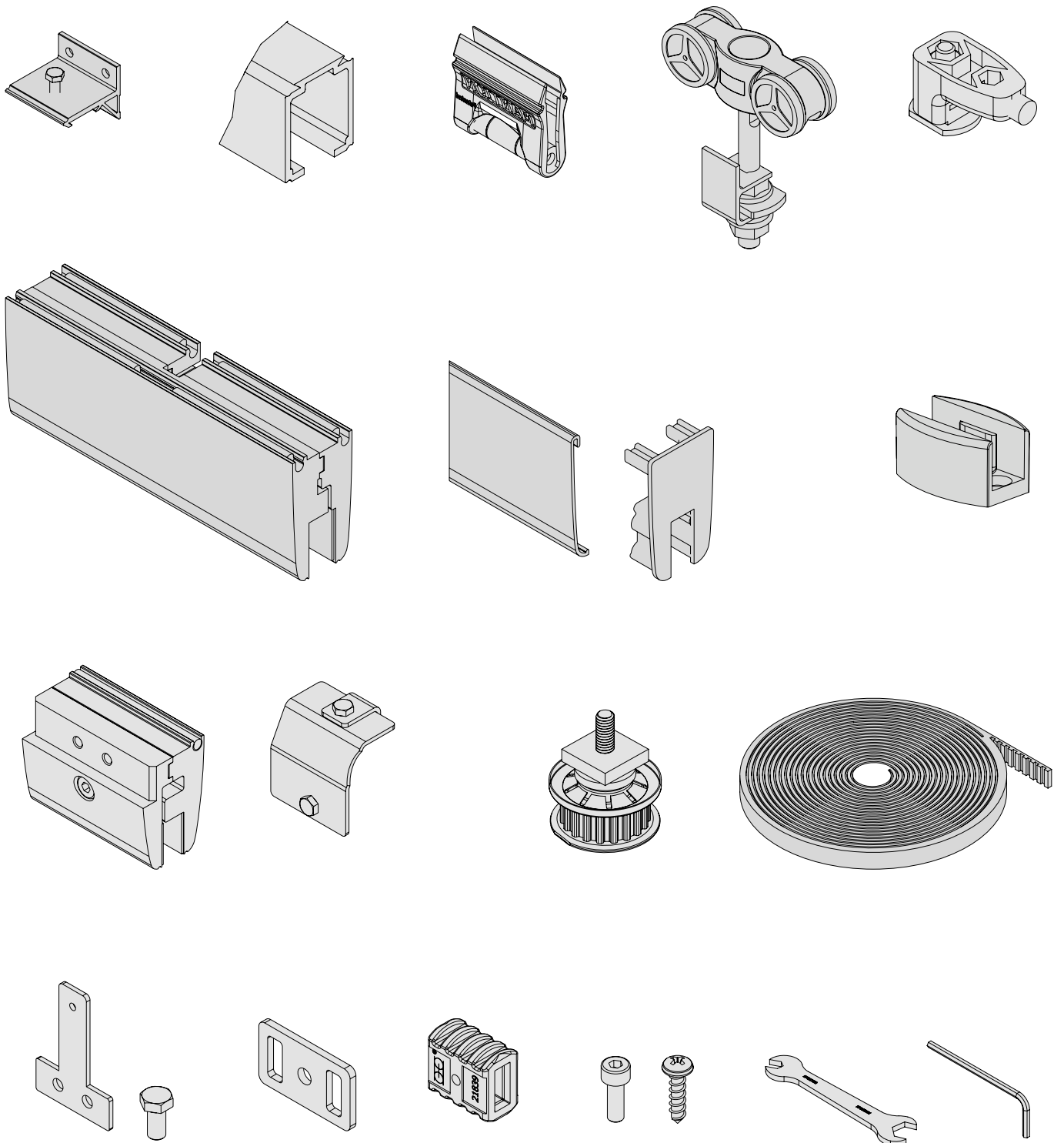

## CONDITIONS DE POSE / MONTAGEBEDINGUNGEN / INSTALLATION REQUIREMENTS / CONDICIONES DE COLOCACION:

- Produit destiné à une utilisation en intérieur / Dieses Produkt ist nur für Innenanwendung geeignet / For indoor use only / Producto para utilización en interior
- Ne pas installer dans des endroits humides / Nicht in feuchten Atmosphären verwenden / Do not install in humid places / No instalar en lugares húmedos
- Le montage doit être effectué par des monteurs qualifiés / Die Montage muss von qualifizierten Handwerkern geführt werden / Installation must be performed by skilled personnel / el montaje tiene que hacerse por instaladores cualificados

## OUTILLAGE NÉCESSAIRE A LA POSE / BENÖTIGTE WERKZEUGE / REQUIRED TOOLS FOR ASSEMBLY / HERRAMIENTA NECESARIA PARA LA COLOCACIÓN:

- Mètre / Metermass / Measuring tape / Flexometro
- Visseuse/perceuse à percussion (selon type de support) / Einschraubmaschine / Schlagbohrer (je nach dem Wandmaterial) / Percussion drill (if needed) / Atornillador / taladro de percusión (en función del soporte)
- Niveau à bulle / Wasserwaage / Spirit level / Nivel de burbuja
- Clés BTR de 3 et 4 / Schlüssel / Allen wrenches (3 and 4 mm) / Llave Allen de 3 y 4

## DIMENSIONS / MASSE / SIZING / DIMENSIONES (mm):

Ecoinçon min. côté moteur / Min. Eckenmasse auf Stauplatzseiten / Min. nook for pushback side / Rincón min. Lado retroceso : **O/2 + 180 mm (SUM300)**  
**O/2 + 200 mm (SUM200)**

Ecoinçon min. / Min. Eckenmasse / Min. nook / Rincón min. : **O/2 + 50 mm**

Linteau min. / Min. Türsturz / Min. lintel / Dintel min: **120 mm**

Hauteur du panneau / Paneelhöhe / Panel height / Altura del panel: **H - 25 mm**

Largeur panneau / Paneelbreite / Panel width / Anchura del panel: **O/2 + 35 mm**

Epaisseur panneau / Paneelstärke / Panel thickness / Grueso del panel: **8-10mm**

Poids panneau / Paneelgewicht / Panel weight / Peso panel: **2 x 50 Kg MAX**

Caractéristiques alimentation / Versorgung / Power supply output current rate / Características de la alimentación: **24V AC/DC 2.5A (SUM300)**  
**230 V AC (SUM200)**



# SUM300

Le moteur peut être situé  
à gauche ou à droite  
Motorization can be on  
the left or right side

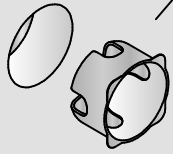
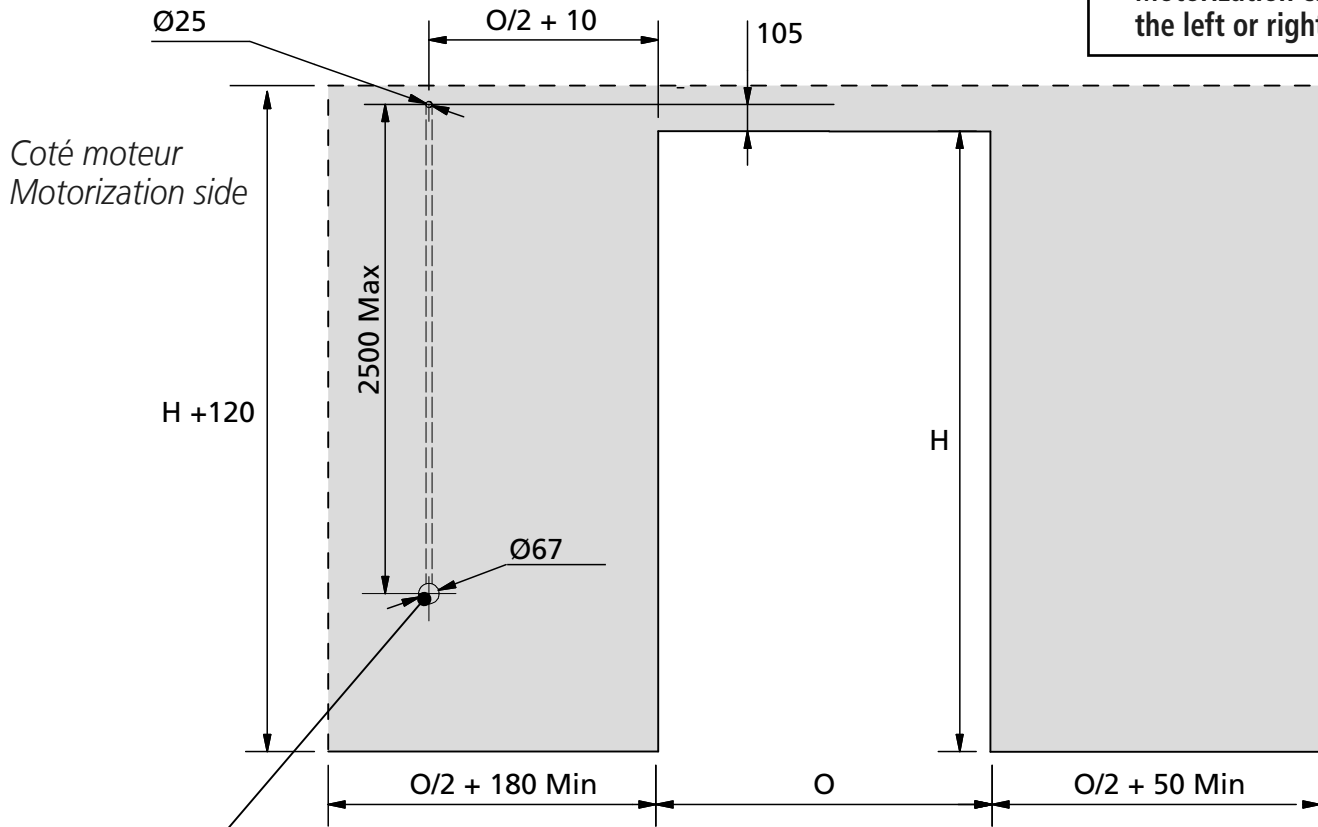

**IMPORTANT:** le boîtier de gestion doit être toujours accessible pour les opérations de réglage et les éventuelles interventions qui pourraient se rendre nécessaires.

**WICHTIG:** die Steuerungseinheit muss für Einstellungen sowie Wartungsarbeit immer zugänglich sein.

**WARNING:** the electronic board must be accessible for any further setting operation

# SUM200

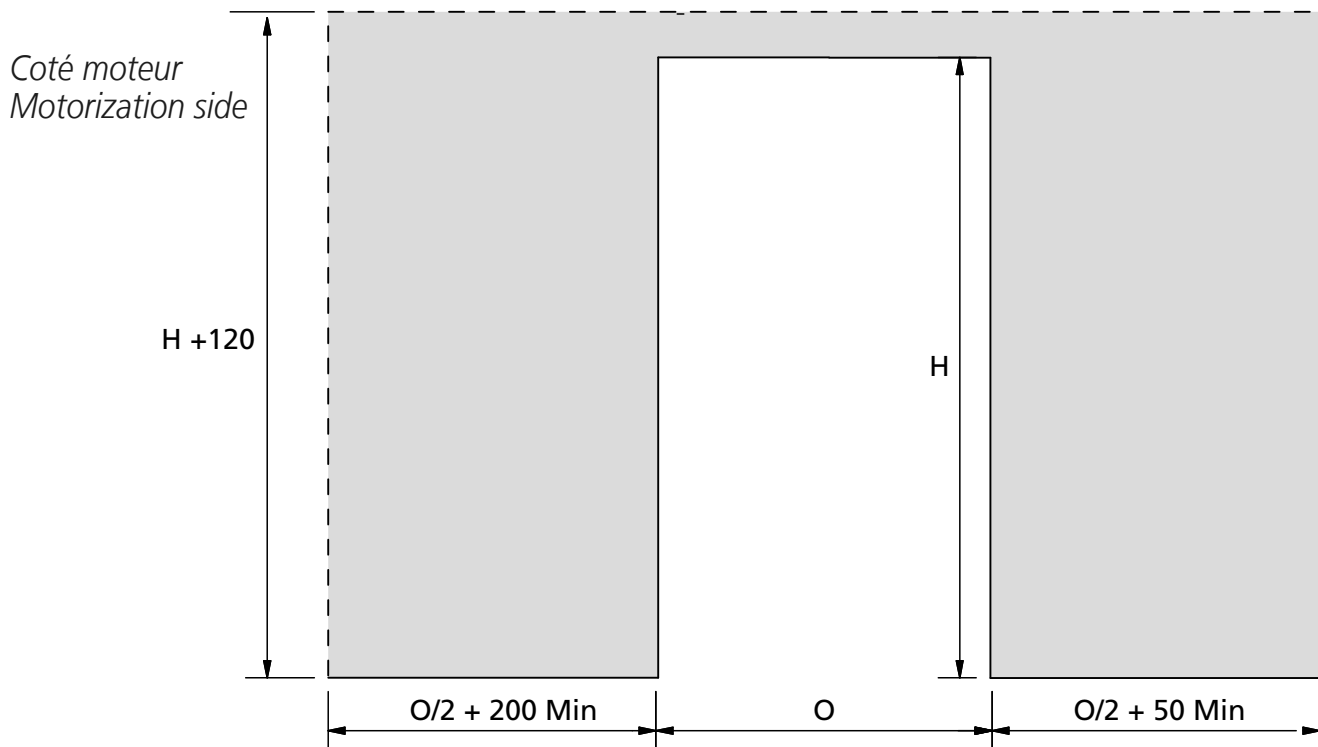

INSTALLATION / MONTAGE / ASSEMBLY / MONTAJE

1.

a

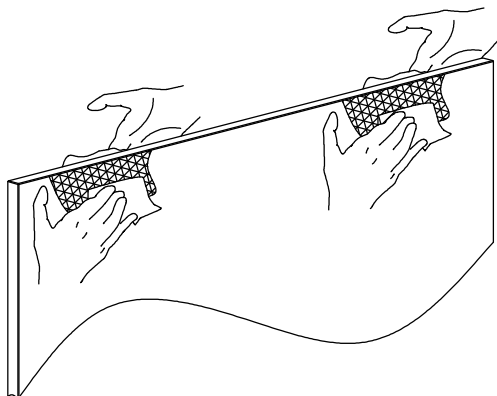

$L = O/2 + 35 \text{ mm}$   
 $W = H - 25 \text{ mm}$

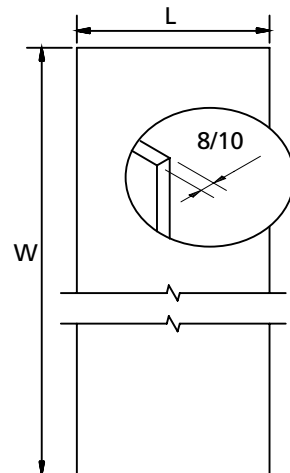

Face 1



b

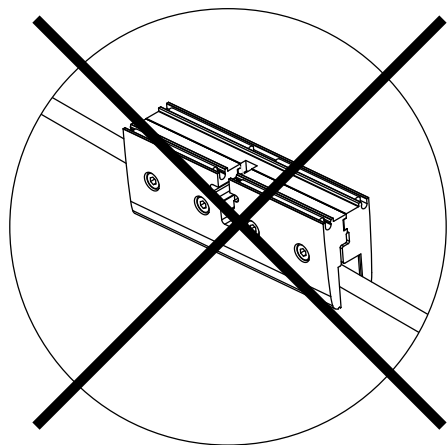
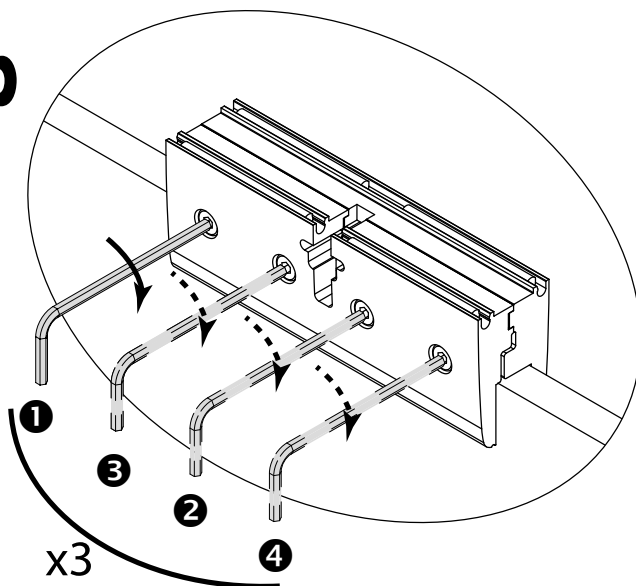

75

9 N.m

Face 1

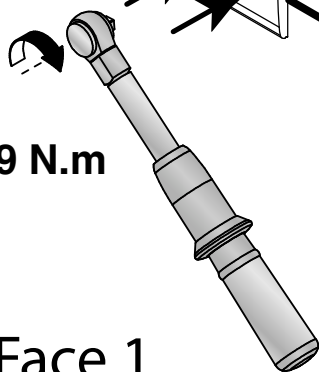

180°

L/2

75

x 2



# 2.

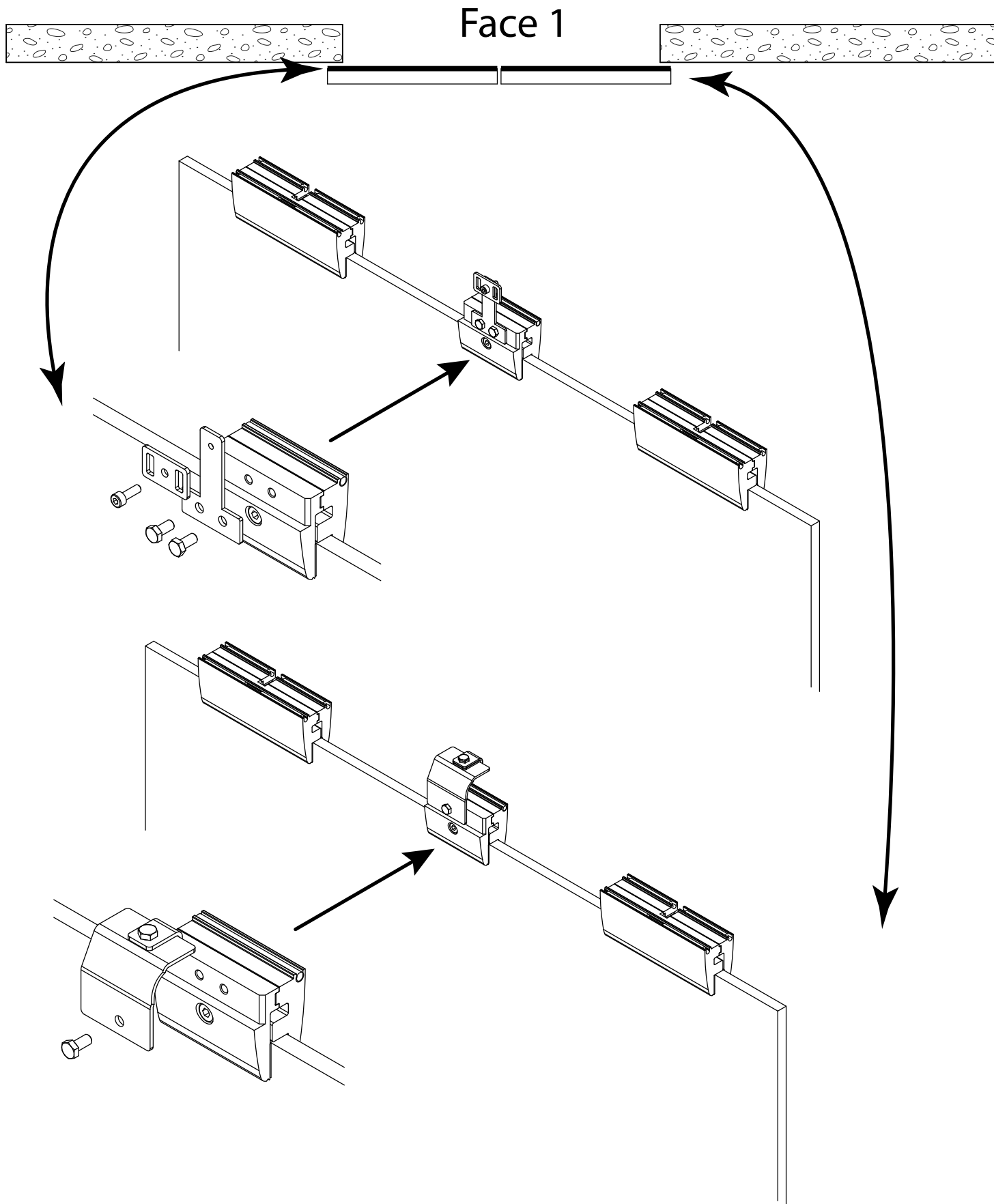

# INSTALLATION / MONTAGE / ASSEMBLY / MONTAJE

**3.**

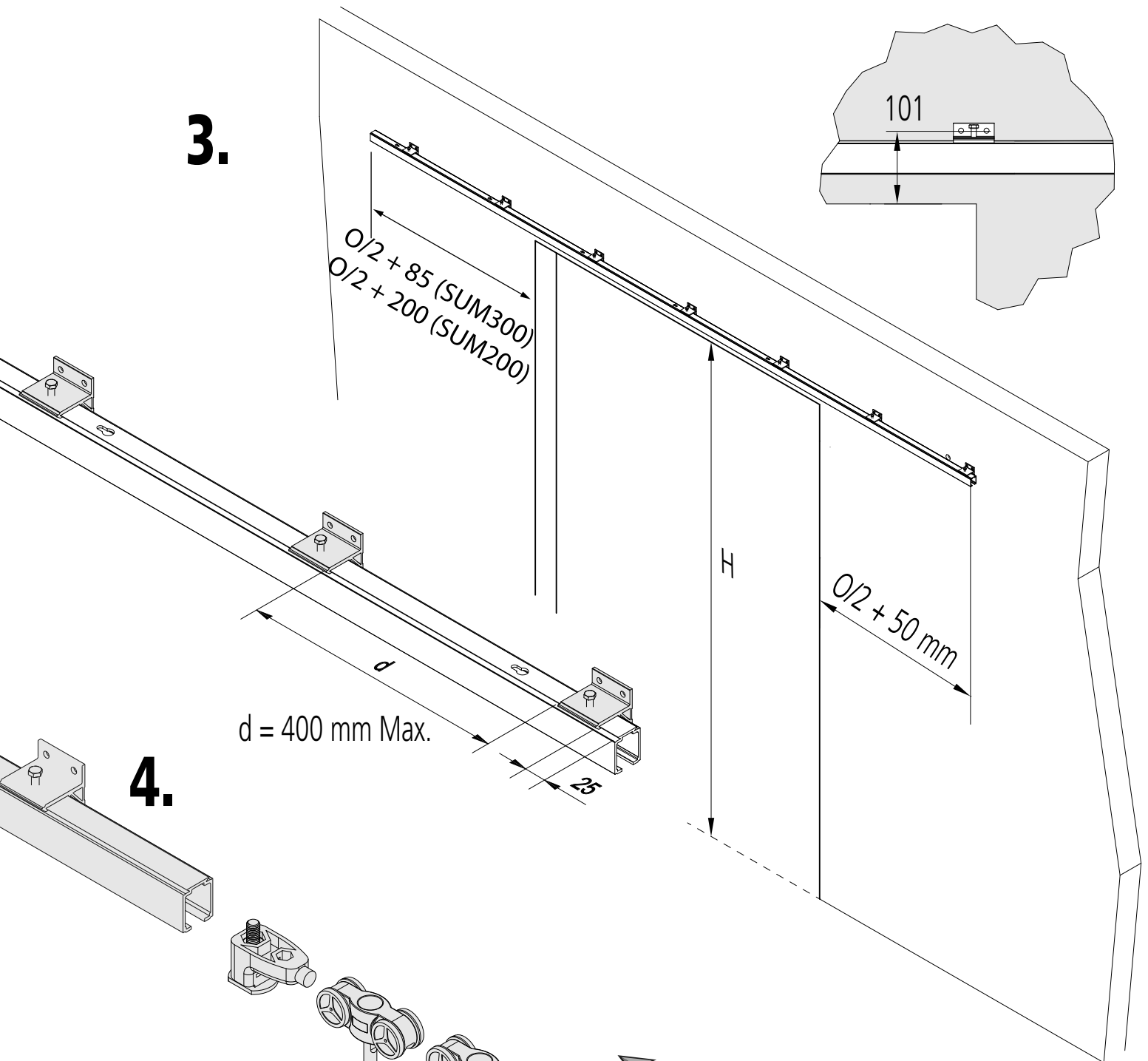

**4.**

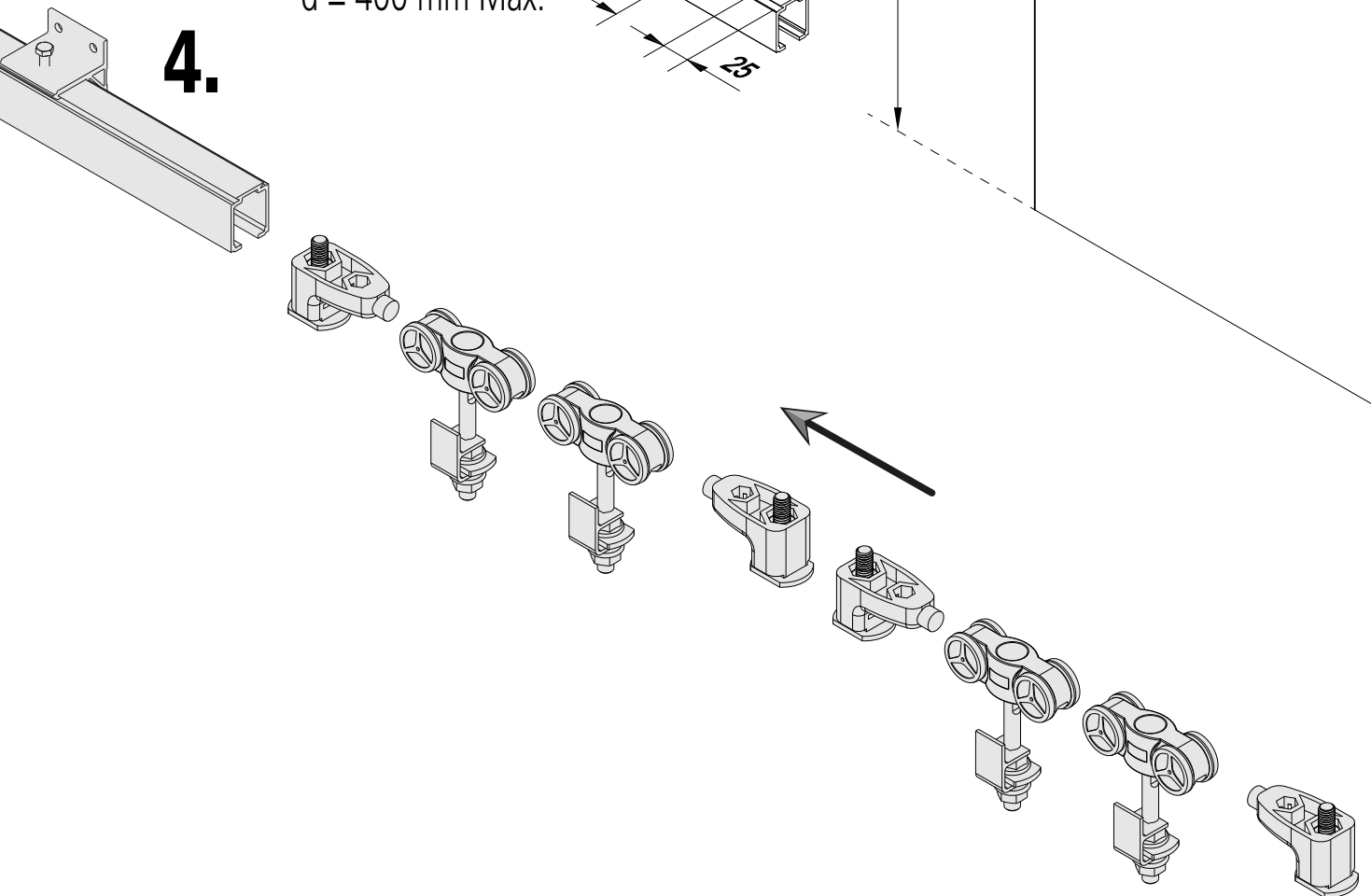

5.

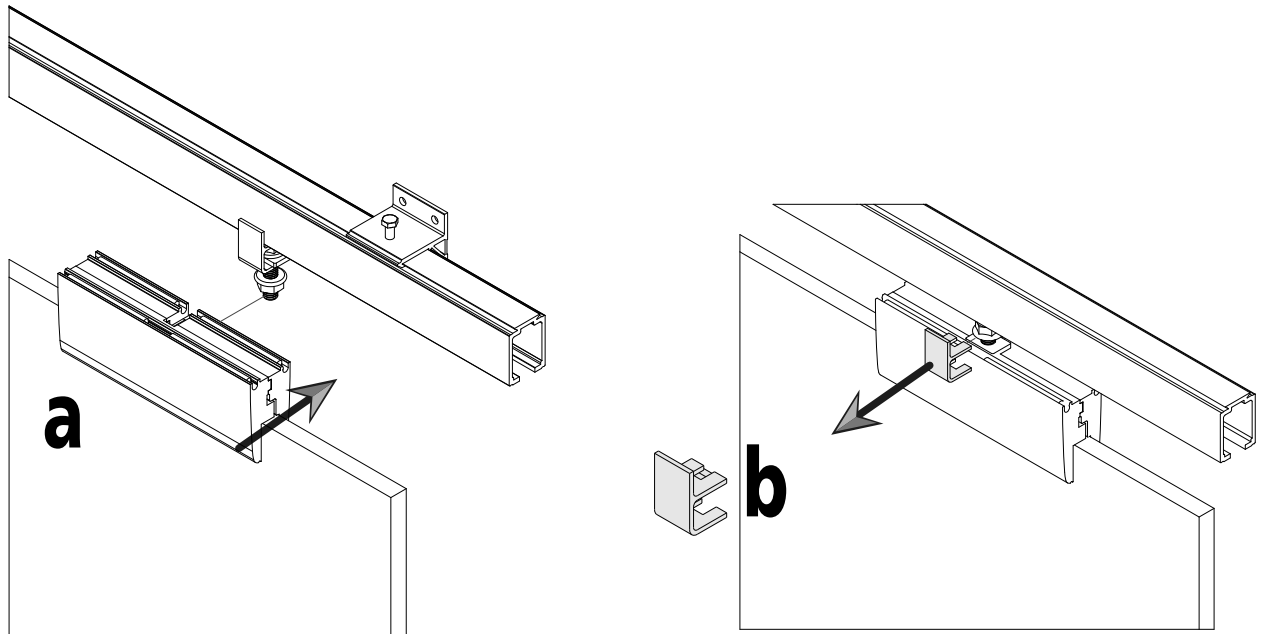

6.

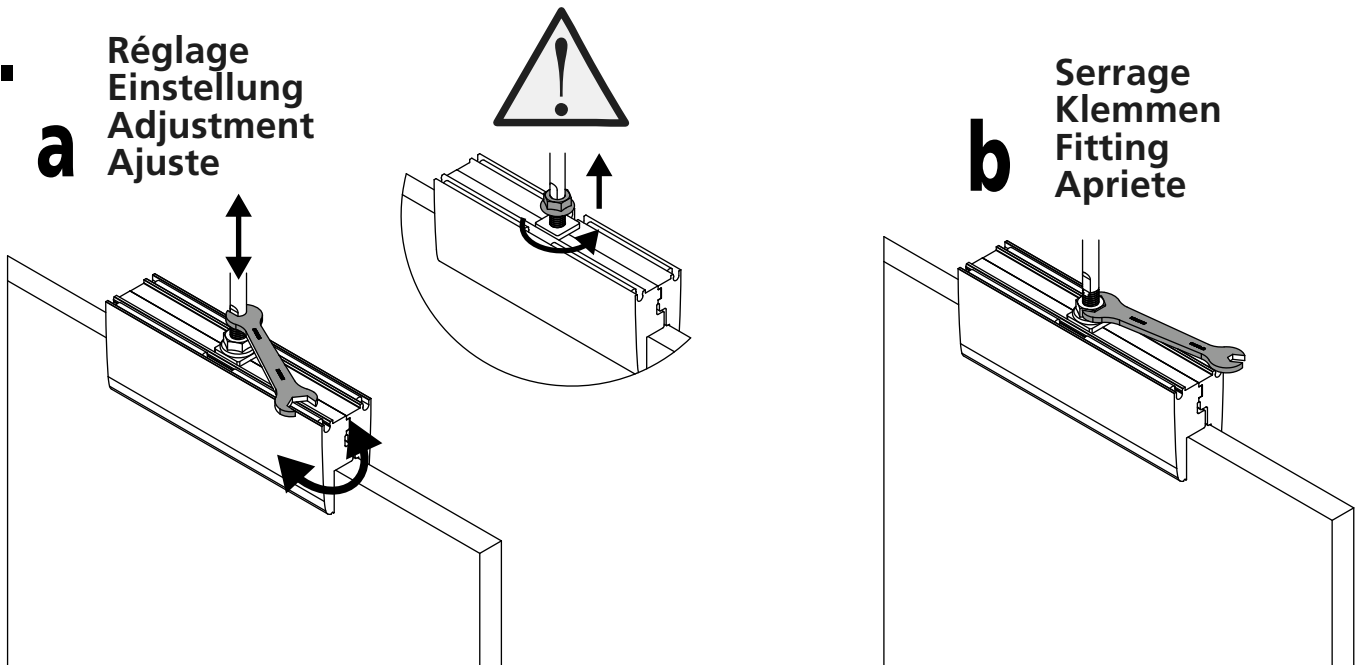

7.

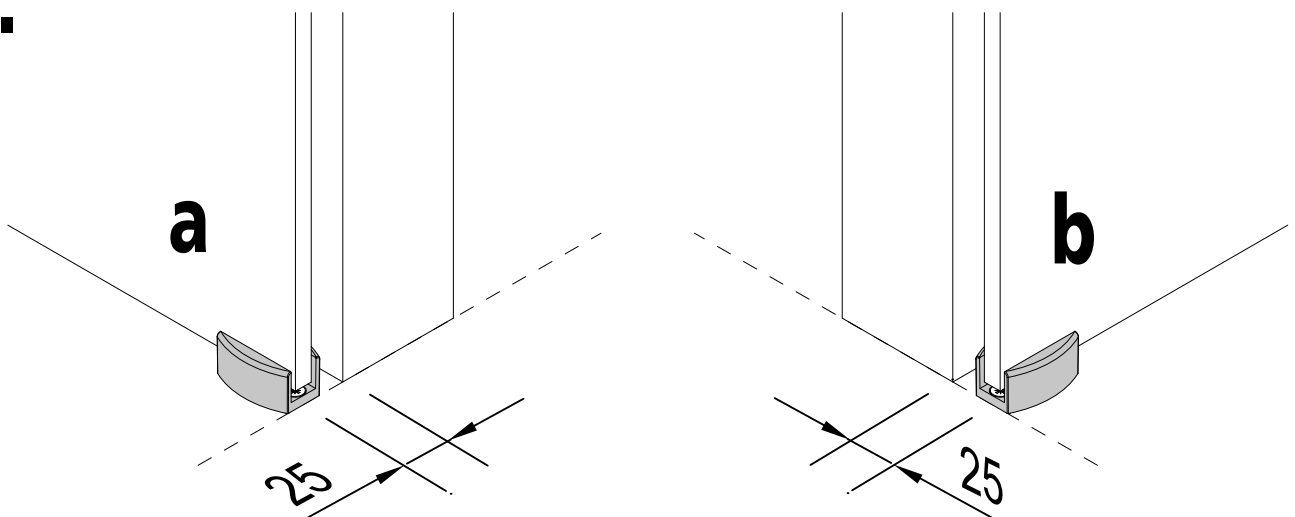



8.

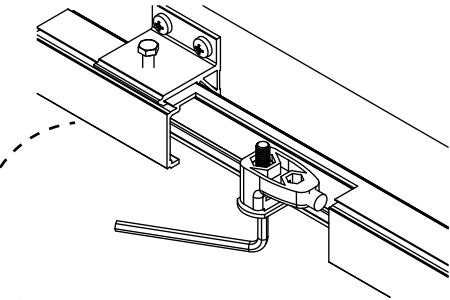

Serrage  
Klemmen  
Fitting  
Apriete

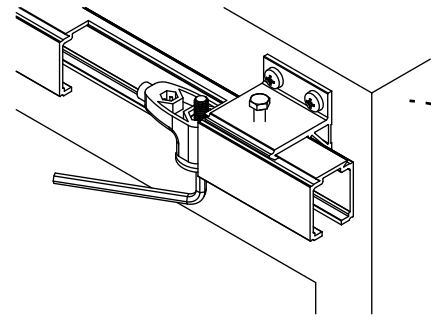
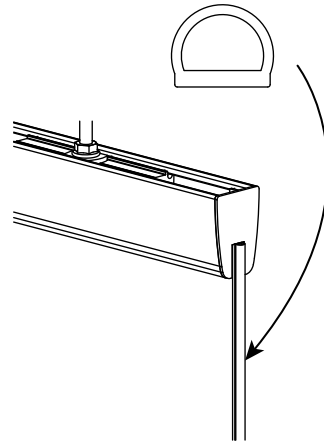

Serrage  
Klemmen  
Fitting  
Apriete

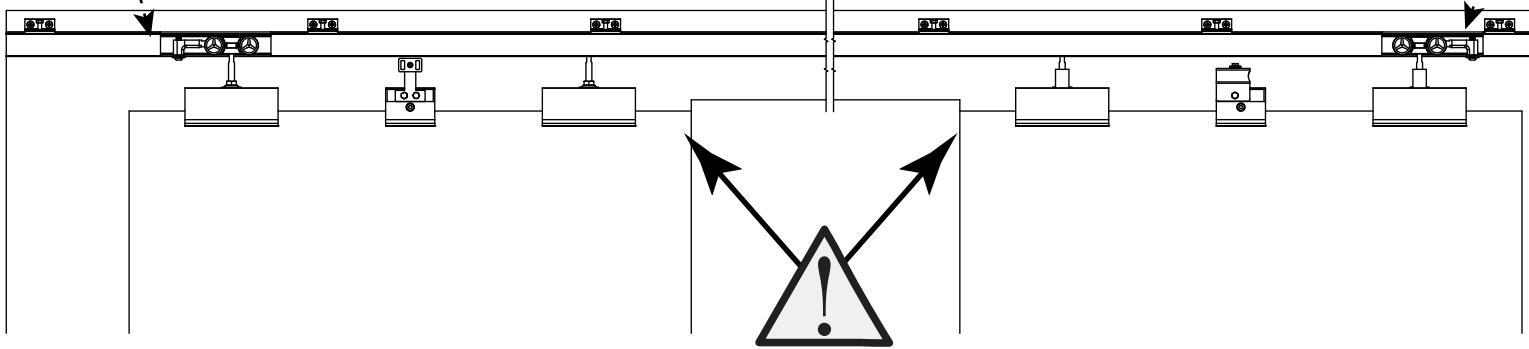

Serrage  
Klemmen  
Fitting  
Apriete

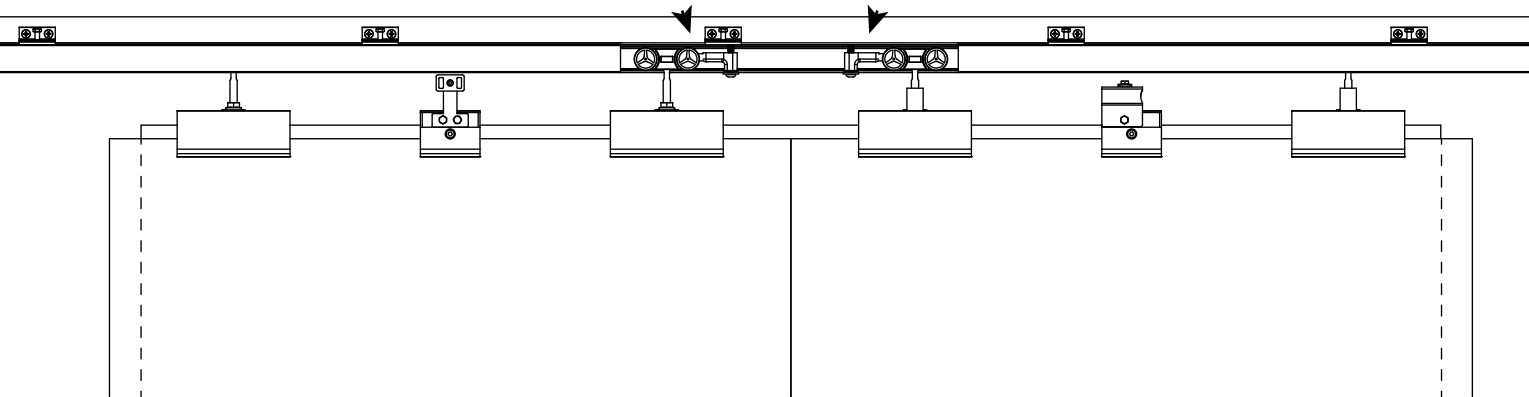

//



9.

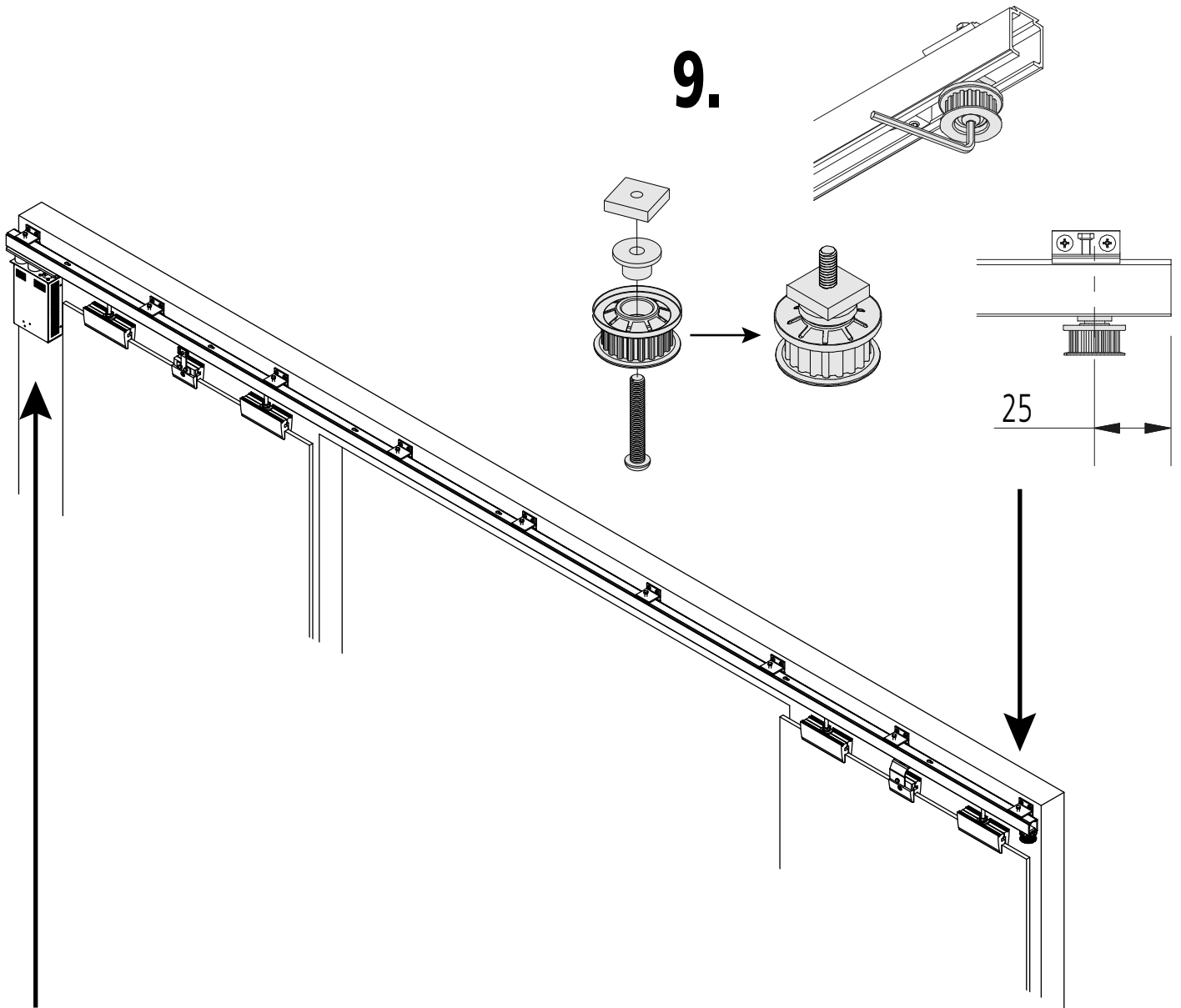

10.

*SUM300*

*SUM200*

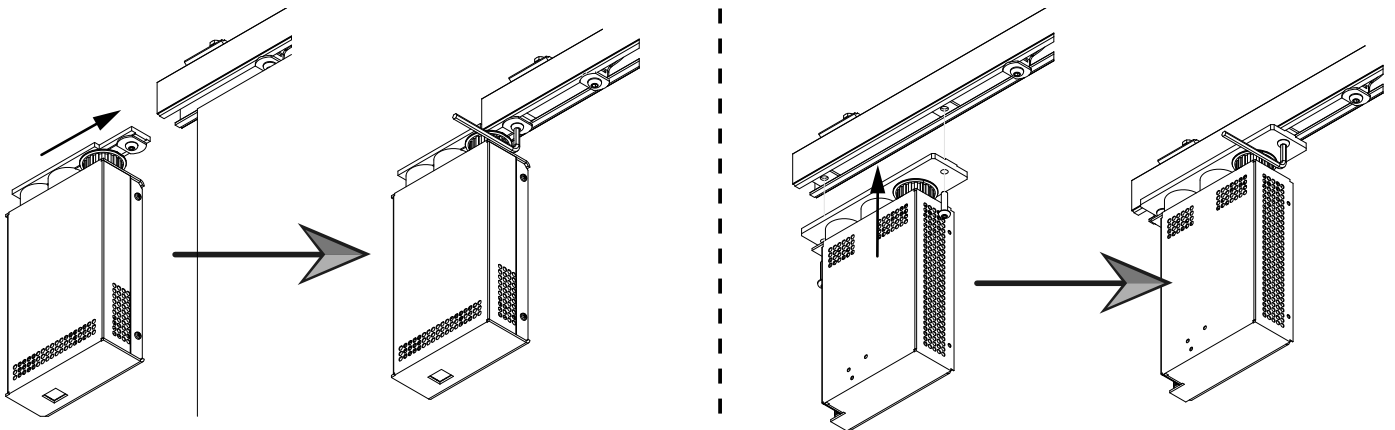

## 11.



Le montage de la courroie doit impérativement se faire : porte en position ouverte ou fermée  
 Die Montage des Riemens soll unbedingt mit geöffneter / oder geschlossener Tür kommen  
 The assembly of the belt necessarily has to be made with opened / or closed door.  
 El montaje de la correa tiene que hacerse imperativamente con puerta en posición abierta o cerrada

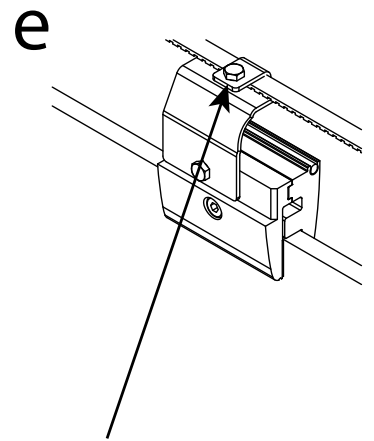
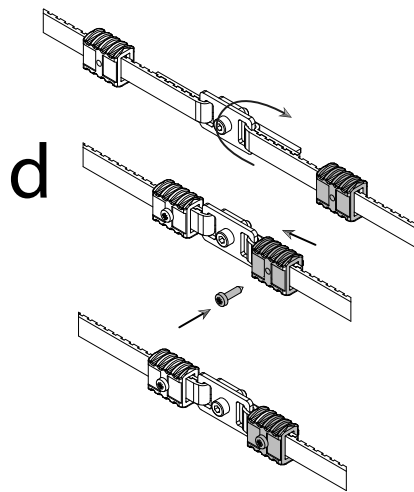
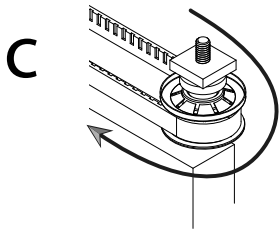
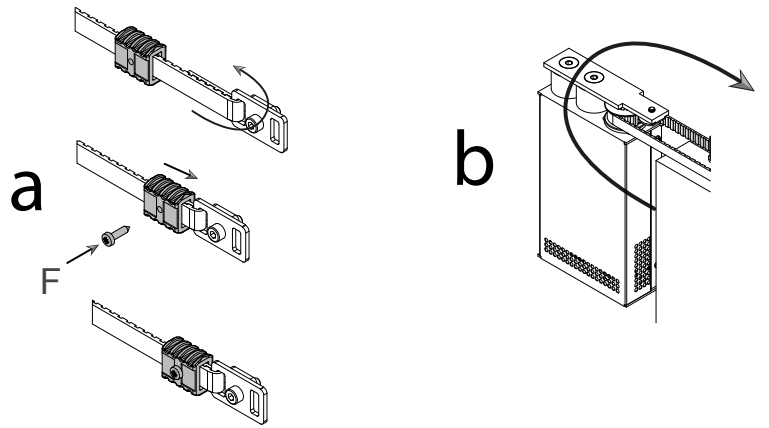

Serrage  
 Klemmen  
 Fitting  
 Apriete

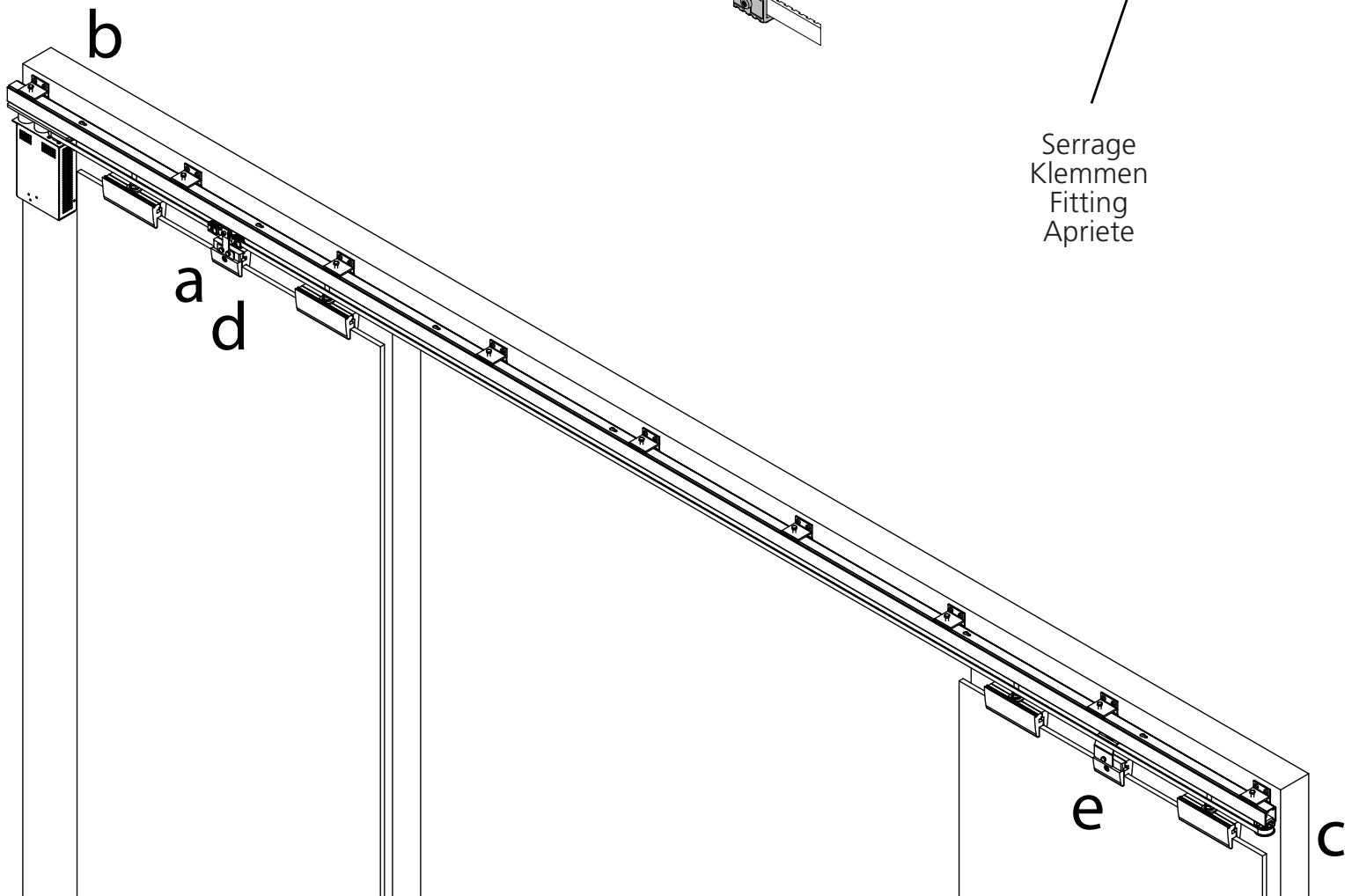

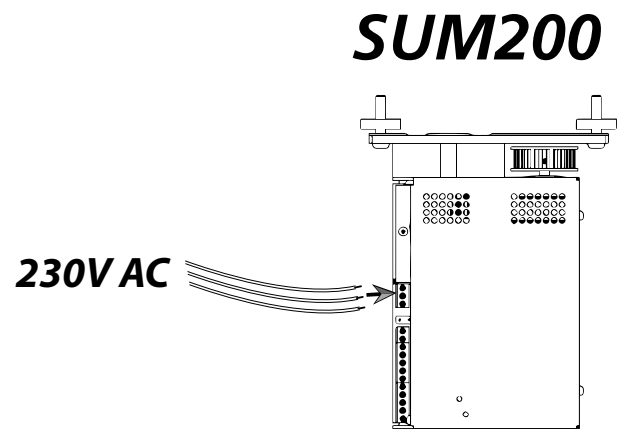
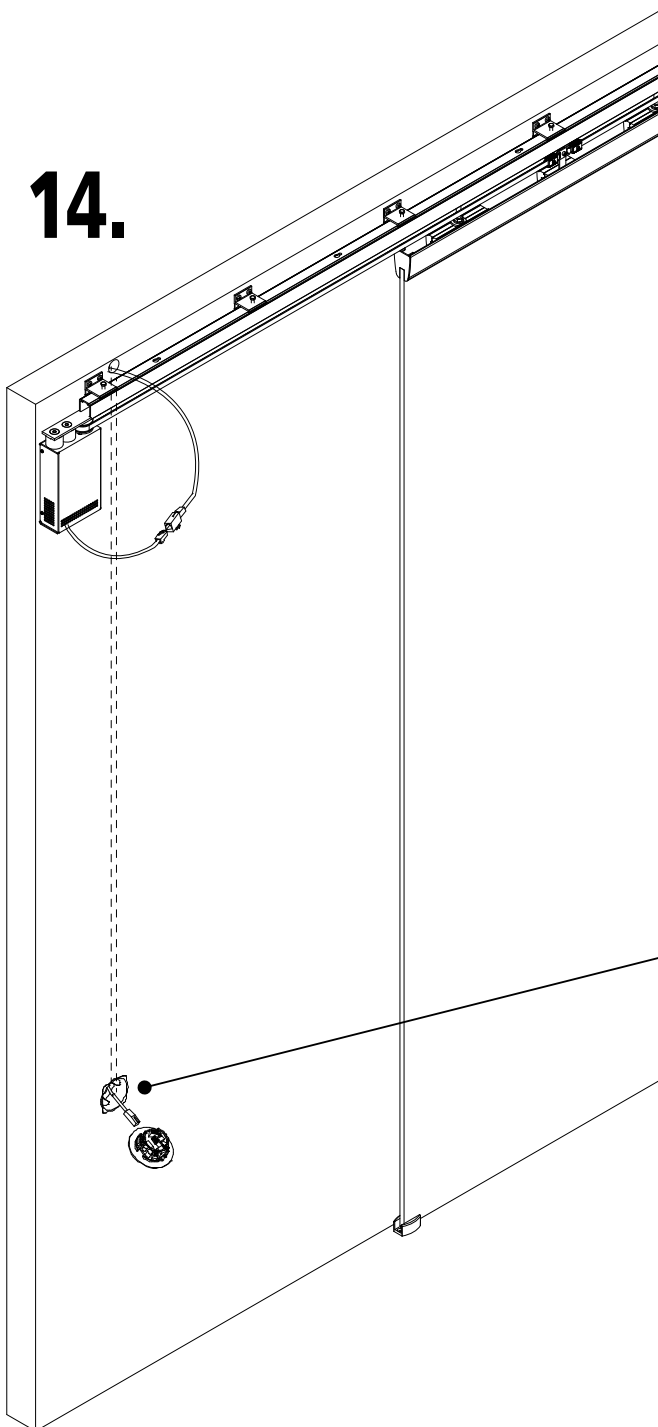
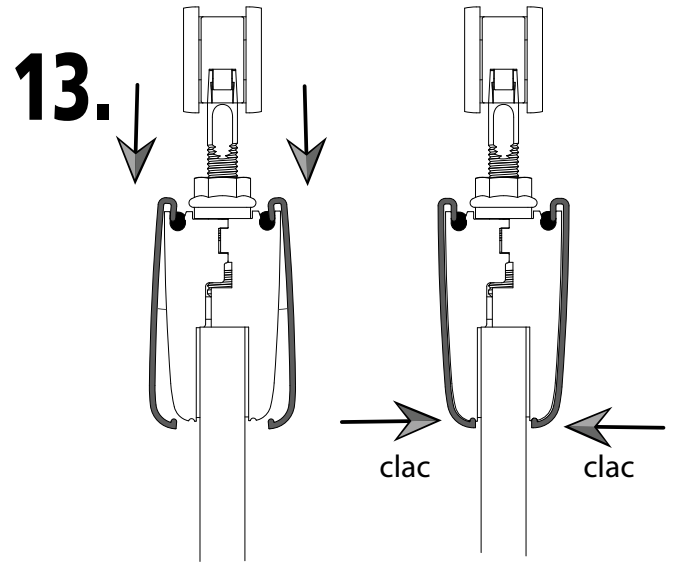
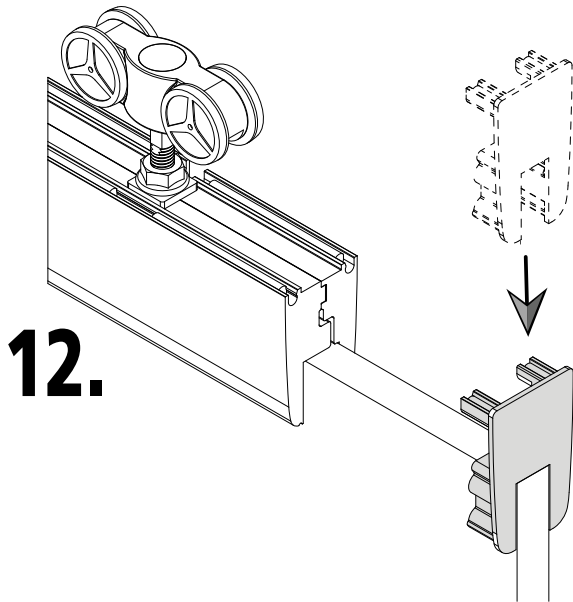

**SUM300**

